

1 dimensions in mm

A

B

C

D

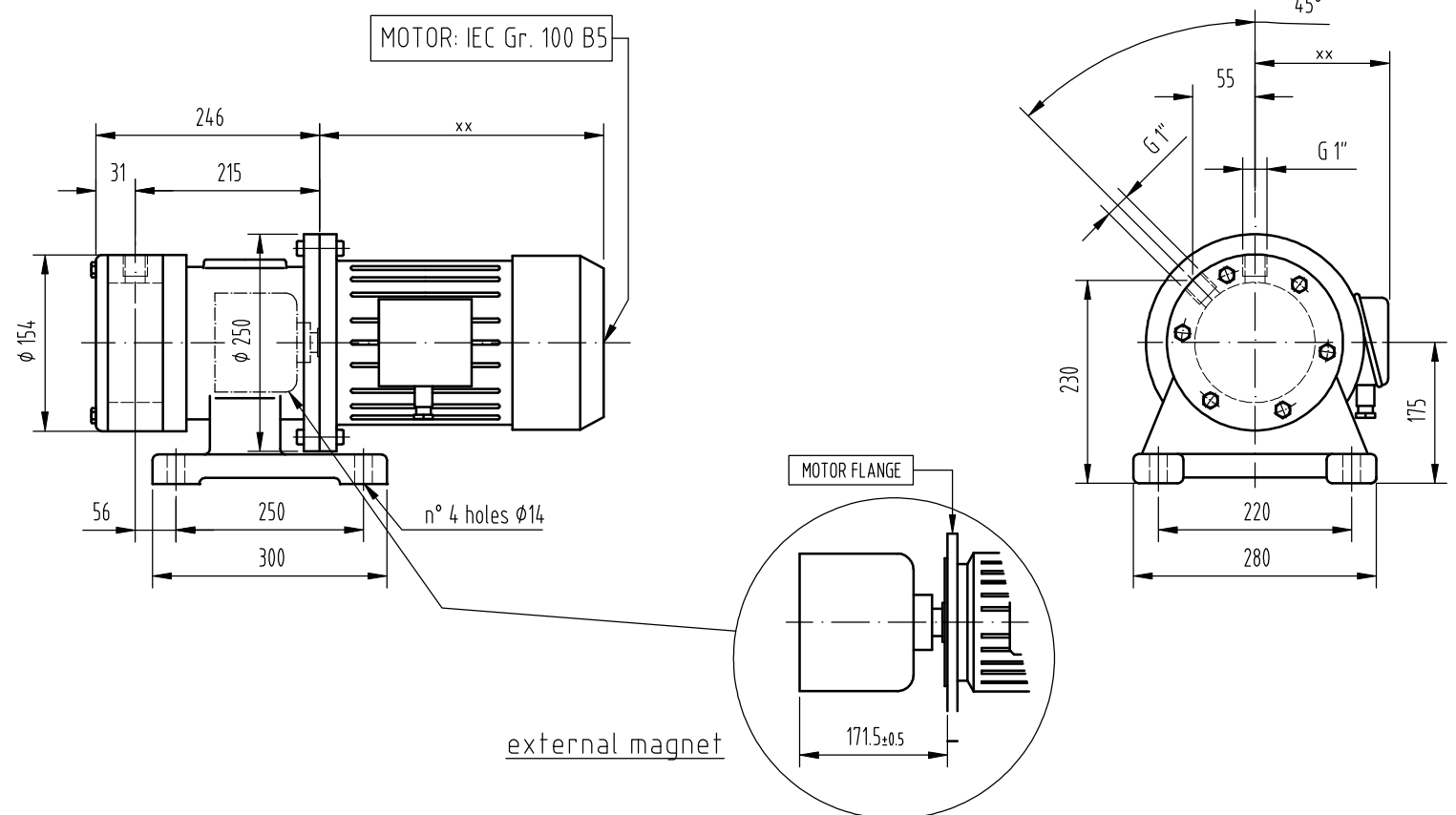

(x) DIFFERENT FROM MOTOR MANUFACTURER
- DIRECTION AND PORTS LOCATION ARE REVERSIBLE

THREAD UNI ISO 228/1

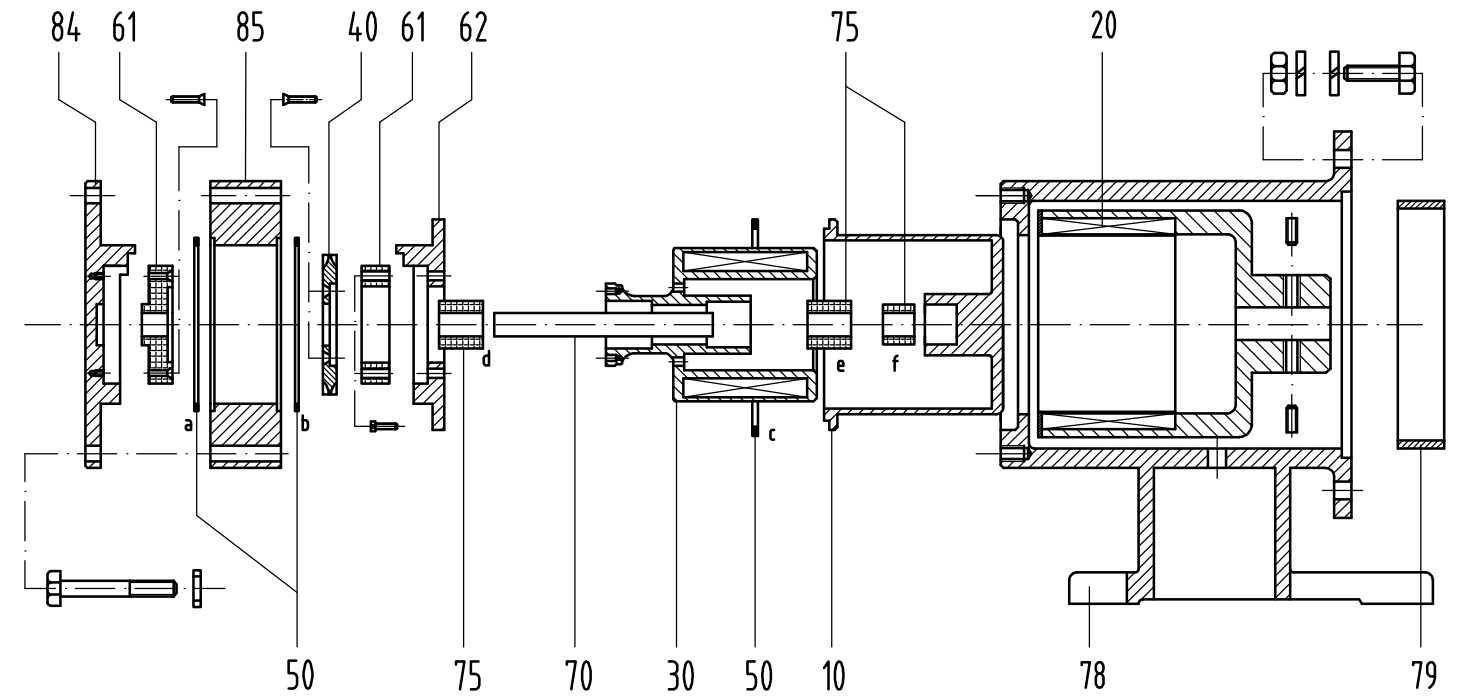

REF	DESCRIPTION	MATERIAL	CODE
10	Containment shell	SS 316L	
20	Ext. Magnet	CoSm/ Carbon Steel	
30	Int. Magnet	SS 316L/CoSm	
40	Impeller	SS 316L	
50	Set O-Rings (a+b+c) a + b = O-Ring 4375 (240) c = O-Ring 4437 (245)	Viton	
61	Thrust Bearings	Pcarbon	
62	Rear Ring	SS316L	
70	Shaft	SIC	
75	Sleeve Bearings Bearings (d+e) Bearing (f)	SIC SS316	
78	Bracket (250-180-28)	Cast Iron	
79	Rub Ring	Bronze	
84	End Cover	SS 316L	
85	Pump Casing	SS 316L	
88	Rear Wet End (10+30+40+50+61+62+70+75)	/	



MARCH PUMPEN GmbH & Co.KG
 Rathenastraße 2
 D-35394 Gießen
 www.march-pumpen.com
 info@march-pumpen.com

Baureihe / Series:	MTA
Typ / Type:	MTA 78 SSR
Motor:	IEC 100 B5

1 2 3 4 5 6